

## Low Loss IGBT

### Features

- High current capability
- low saturation voltage:  $(V_{CE(sat)}=2.3@I_C=40A)$
- High input impedance
- Fast switching
- RoHS compliant

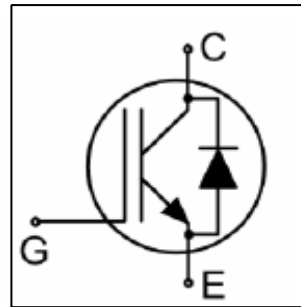

### Applications

- Induction Heating
- UPS
- SMPS
- PFC

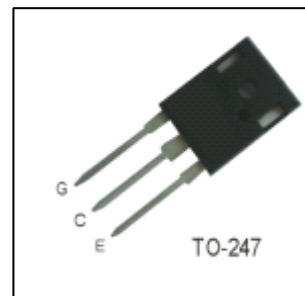

### Absolute Maximum Ratings ( $T_C=25^\circ\text{C}$ )

Symbol	Parameter		Value	Unit
$V_{CES}$	Collector-Emitter Voltage		600	V
$I_C$	DC Collector Current	$T_C=25^\circ\text{C}$	80	A
		$T_C=100^\circ\text{C}$	40	A
$I_{CM(1)}$	Pulsed Collector Current	$T_C=25^\circ\text{C}$	120	A
$V_{GES}$	Gate-Emitter Voltage		$\pm 20$	V
$P_D$	Maximum Power Dissipation	$T_C=25^\circ\text{C}$	290	W
	Maximum Power Dissipation	$T_C=100^\circ\text{C}$	116	W
$T_J$	Operation Junction Temperature		-55~ 150	$^\circ\text{C}$
$T_{STG}$	Storage Temperature		-55 ~ 150	$^\circ\text{C}$
$T_L$	Maximum Lead Temperature for Soldering Purposes, 1/8 from case for 5 seconds		300	$^\circ\text{C}$

### Thermal Characteristics

Symbol	Parameter	Value			Unit
		Min	Typ	Max	
$R_{QJC(IGBT)}$	Thermal Resistance, Junction -to -Case	-	-	0.43	$^\circ\text{C/W}$
$R_{QJC(Diode)}$	Thermal Resistance, Junction-to-Case			1.45	$^\circ\text{C/W}$
$R_{QJA}$	Thermal Resistance, Junction-to -Ambient	-	-	40	$^\circ\text{C/W}$

## Electrical Characteristics(Tc=25°C)

Characteristics		Symbol	Test Condition	Min	Typ	Max	Unit
G-E leakage current		$I_{GES}$	$V_{GE}=V_{GES}, V_{CE}=0V$	-	-	±400	nA
Collector-Emitter Breakdown Voltage		$V_{(BR)CES}$	$I_C=0.5mA, V_{GE}=0V$	600	-	-	V
Temperature Coefficient of Breakdown voltage		$\frac{\Delta BV_{CES}}{\Delta T_J}$	$V_{GE}=0V, I_C=250\mu A$	-	0.6	-	
Collector-Emitter Saturation Voltage		$V_{CE(sat)}$	$I_C=40A, V_{GE}=15V$	-	2.3	2.9	
			$I_C=40A, V_{GE}=15V$ $T_c=125^\circ C$	-	2.5	-	
Collector Cut-off current		$I_{CES}$	$V_{CE}=V_{CES}, V_{GE}=0V$	-	-	250	mA
G-E threshold voltage		$V_{GE(th)}$	$V_{CE}=V_{GE}, I_C=250\mu A$	4.0	5.0	6.5	V
Input capacitance		$C_{iss}$	$V_{CE}=30V$ $V_{GE}=0V,$ $f=1MHz$	-	2110	-	pF
Reverse transfer capacitance		$C_{rss}$		-	60	-	
Output capacitance		$C_{oss}$		-	200	-	
Switching time	Turn-on delay time	$T_d(on)$	$V_{CE}=400, I_C=40A$ $R_G=10\Omega, V_{GE}=15V$ Inductive Load, $T_c=25^\circ C$	-	25	-	ns
	Turn-on Rise time	$t_r$		-	42	-	
	Turn-off delay time	$T_d(off)$		-	115	-	
	Turn-off Fall time	$t_f$		-	27	54	
Turn-on energy		$E_{on}$		-	1.13	-	mJ
Turn-off energy		$E_{off}$		-	0.31	-	
Total switching energy		$E_{ts}$		-	1.44	-	
Switching time	Turn-on delay time	$T_d(on)$		$V_{CE}=400, I_C=40A$ $R_G=10\Omega, V_{GE}=15V$ Inductive Load, $T_c=125^\circ C$	-	24	-
	Turn-on Rise time	$t_r$	-		43	-	
	Turn-off delay time	$T_d(off)$	-		120	-	
	Turn-off Fall time	$t_f$	-		30	-	
Turn-on energy		$E_{on}$	-		1.14	-	mJ
Turn-off energy		$E_{off}$	-		0.48	-	
Total switching energy		$E_{ts}$	-		1.62	-	
Total Switching Loss		$Q_g$	-		120	-	nC
Gate to Emitter Charge		$Q_{ge}$	$V_{CE}=400V, I_C=40A,$ $V_{GE}=15V$	-	14	-	
Gate to Collector Charge		$Q_{gc}$	-	58	-		

## Anti-Parallet Diode Characteristics (Ta=25°C)

Characteristics	Symbol	Test Condition	Min	Type	Max	Unit	
Forward voltage(diode)	$V_{FM}$	$I_F=20A$	$T_c=25^\circ C$	-	1.95	2.6	V
			$T_c=125^\circ C$	-	1.85	-	
Reverse recovery time	$t_{rr}$	$I_{ES}=20A, di_{ES} / dt = 200 A / \mu s$	$T_c=25^\circ C$	-	45	-	ns
			$T_c=125^\circ C$	-	140	-	
Reverse recovery charge	$Q_{rr}$	$I_{ES}=20A, di_{ES} / dt = 200 A / \mu s$	$T_c=25^\circ C$	-	75	-	$\mu C$
			$T_c=125^\circ C$	-	375	-	

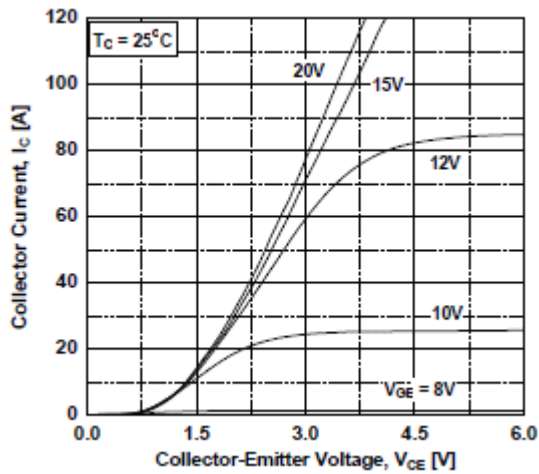

**Fig.1 Typical Out Characteristics**

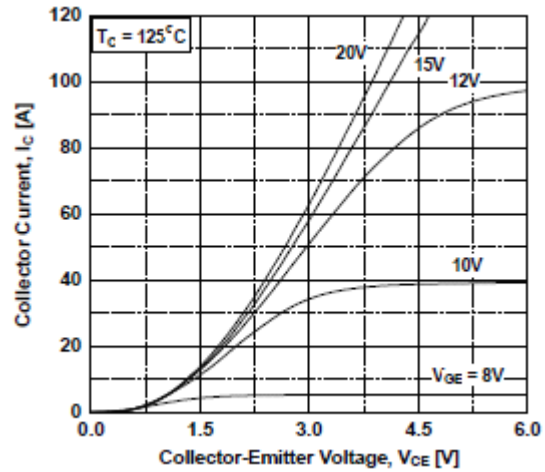

**Fig.2 Typical output Characteristics**

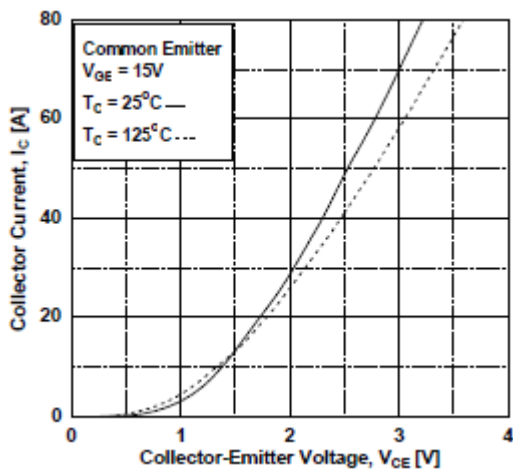

**Fig.3 Typical Saturation Voltage characteristics**

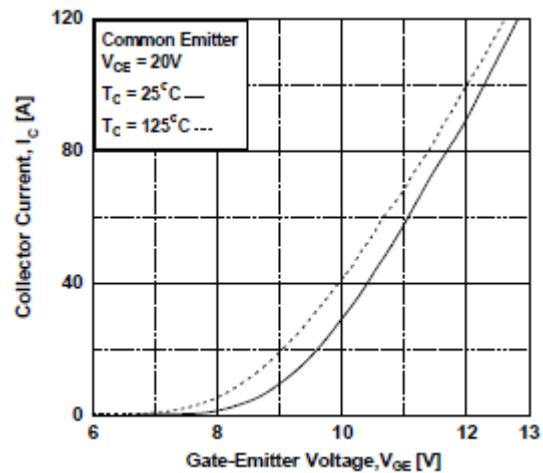

**Fig.4 Transfer characteristics**

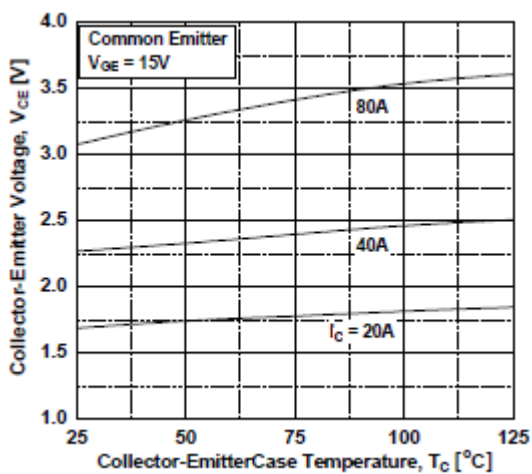

**Fig.5 Saturation Voltage vs. Case Temperature at Variant current level**

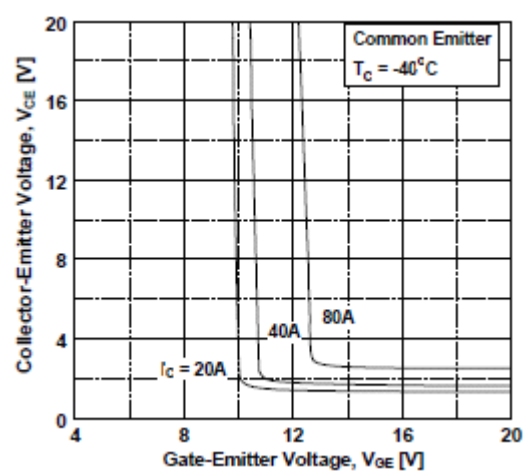

**Fig.6 Saturation Voltage vs.  $V_{GE}$**

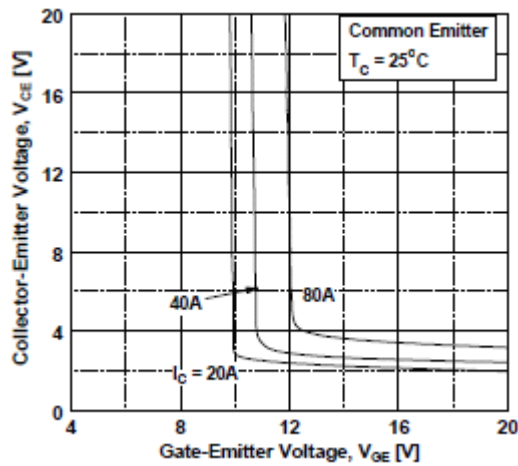

**Fig.7 Saturation Voltage vs.  $V_{GE}$**

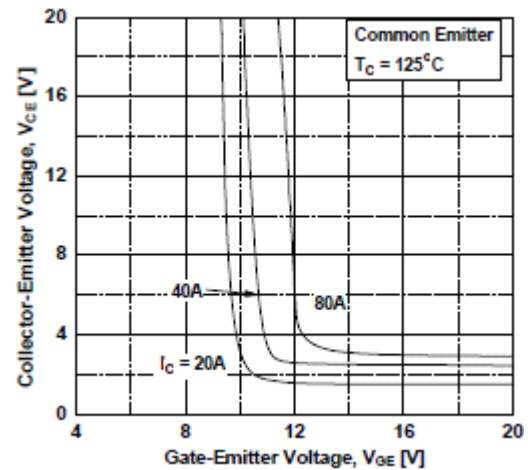

**Fig.8 Saturation Voltage vs.  $V_{GE}$**

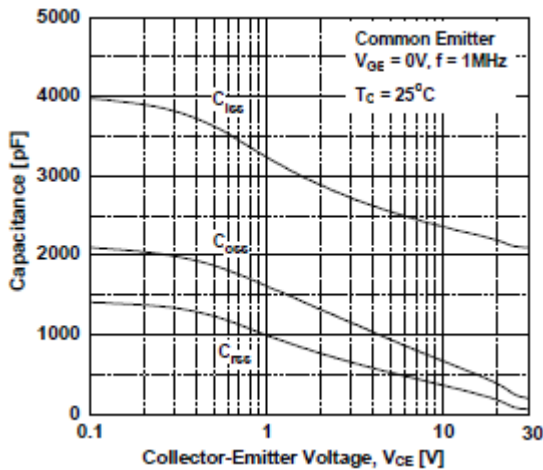

**Fig.9 Capacitance Characteristics**

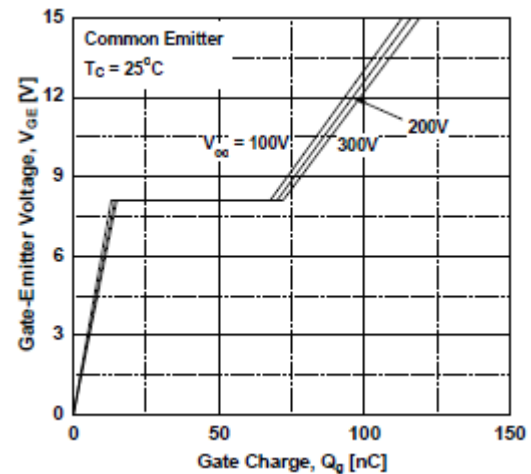

**Fig.10 Gate Charge Characteristics**

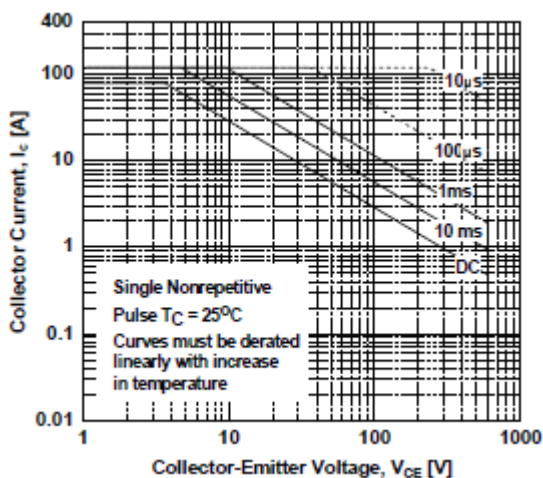

**Fig.11 SOA Characteristics**

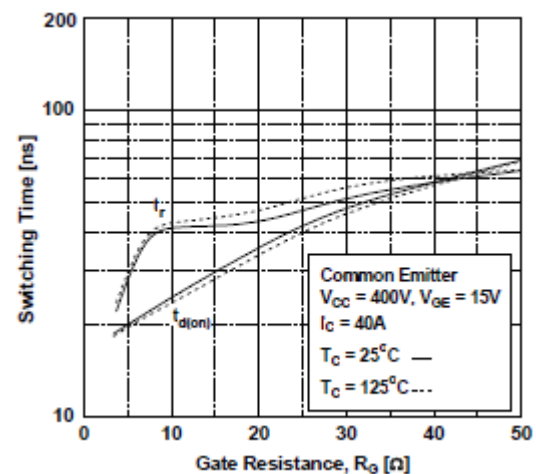

**Fig.12 Turn-on Characteristics vs. Gate Resistance**

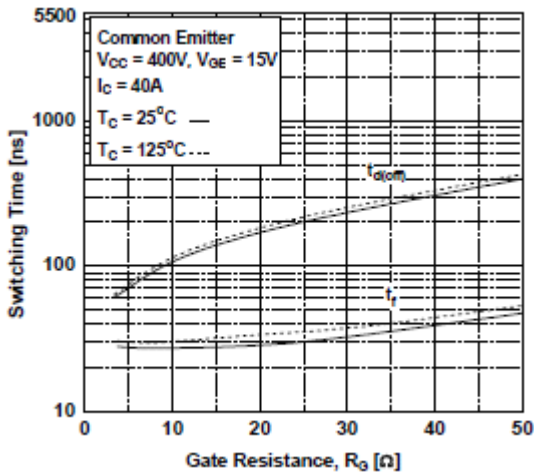

Fig.13 Turn-off Characteristics vs. Gate Resistance

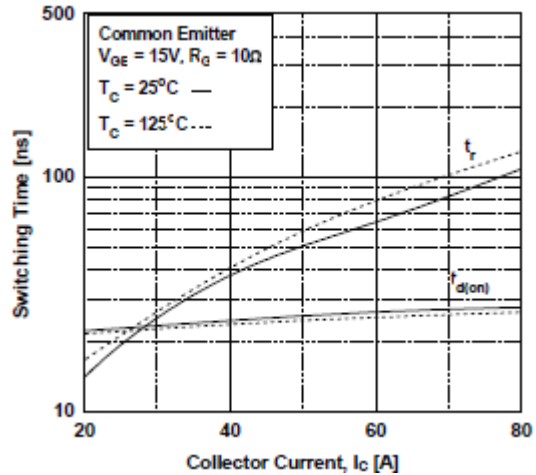

Fig.14 Turn-on characteristics vs. Collector Current

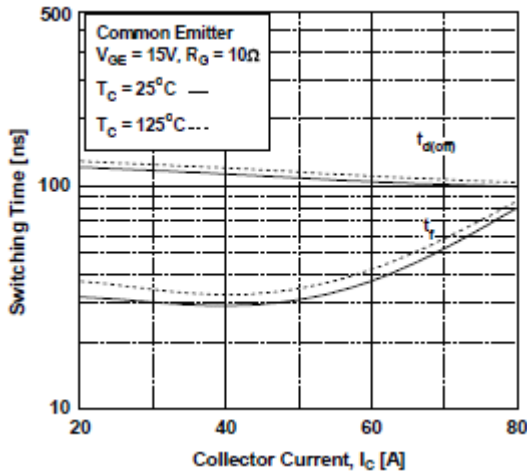

Fig.15 Turn-off characteristics vs. Collector Current

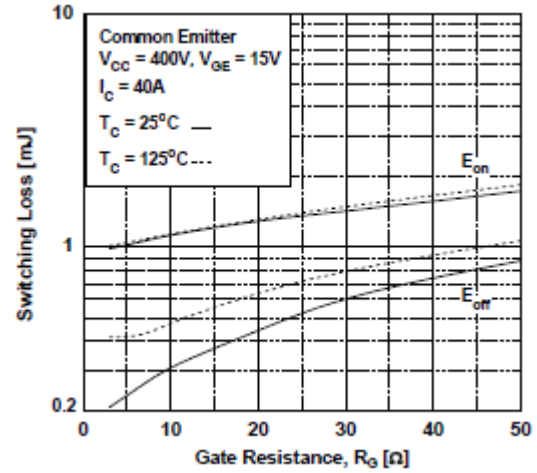

Fig.16 Switching Loss vs. Gate Resistance

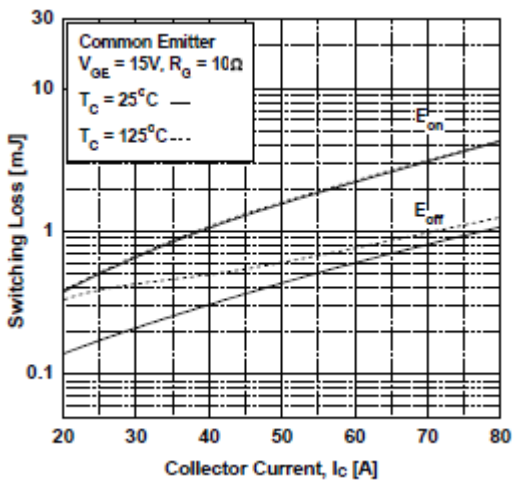

Fig.17 Switching Loss vs. Collector Current

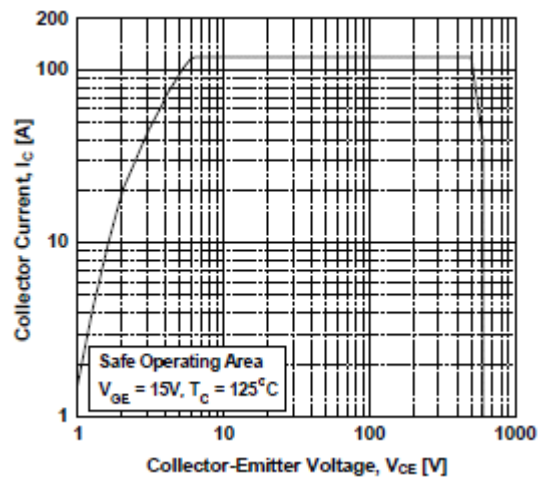
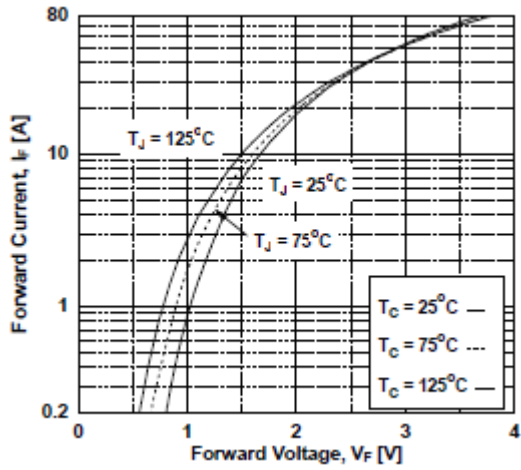
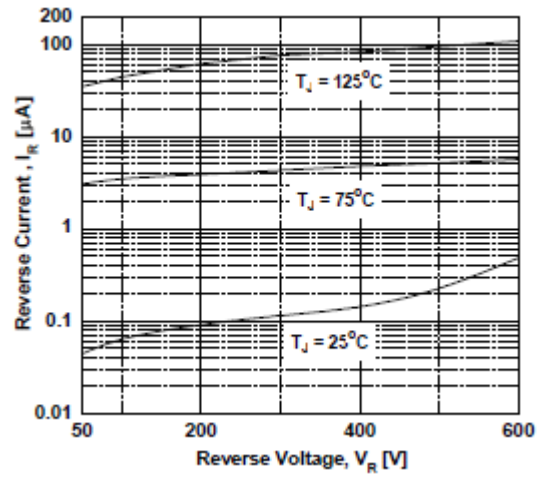

Fig.18 Turn-off Switching SOA Characteristics



**Fig.19 Forward Characteristics**



**Fig.20 Typical Reverse Current vs. Reverse Voltage**

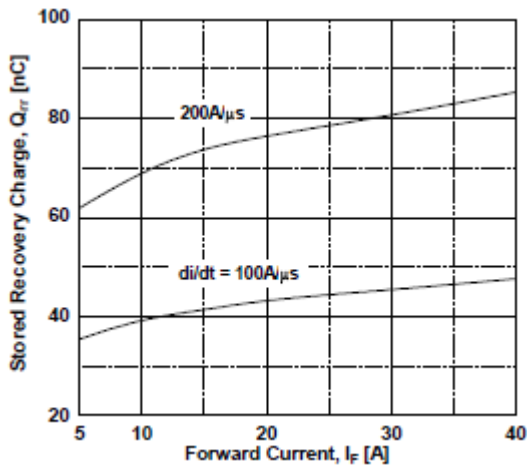

**Fig.21 Stored Charge**

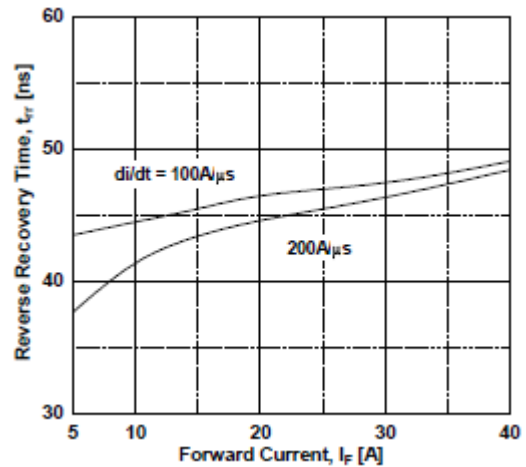

**Fig.22 Reverse Recovery time**

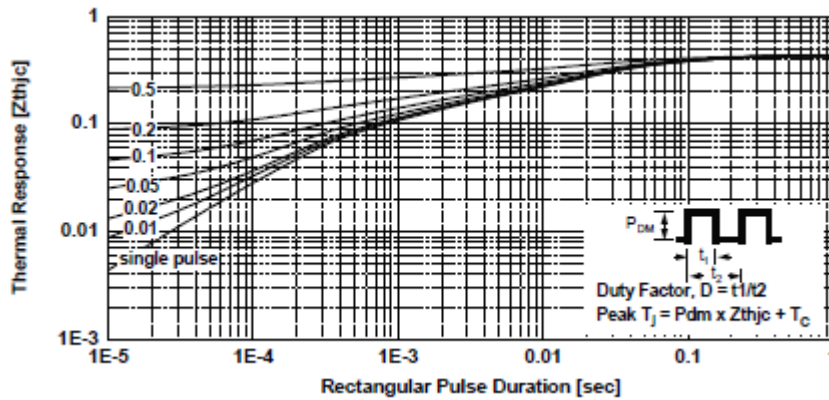

**Fig.23 Transient Thermal Impedance of IGBT**

**TO-247 Package Dimension**

